

Rev.	Description	Initiator	Date
05	ECO 21276; REPLACED 3700-20-5756 WITH 5756. ADDED NOTE TO CONTACT APPLICATIONS ENGINEERING.	LJH	6/14/2023

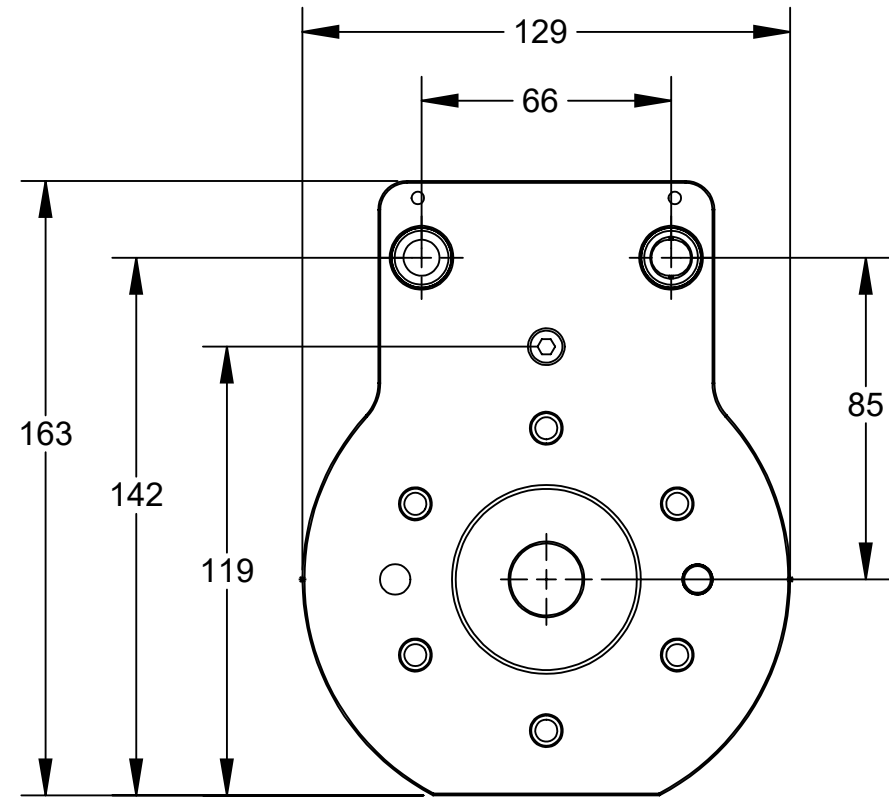

Serviceable Items			
ITEM NO.	QTY.	PART NUMBER	DESCRIPTION
1	1	3700-20-5200	Elongated Drill Bushing 3/8" dia, 5/8 OD, 1/2" long
2	1	3700-20-5230	Drill Bushing 3/8ID x 5/8OD x 1/2 L
3	1	3700-20-11225	TSS Alignment Pin

Note: Contact ATI Application Engineering for questions about previous designs.

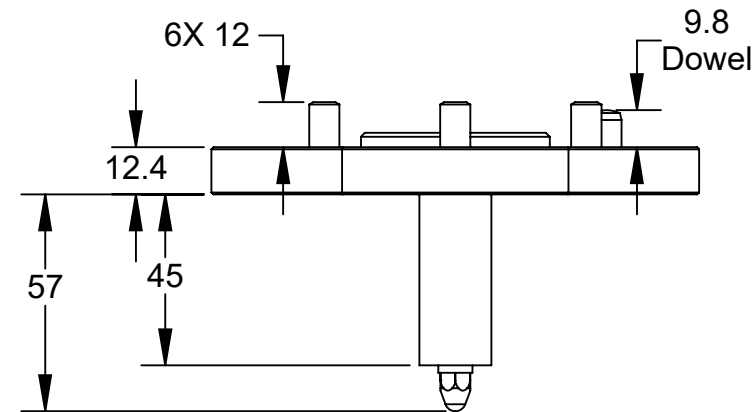
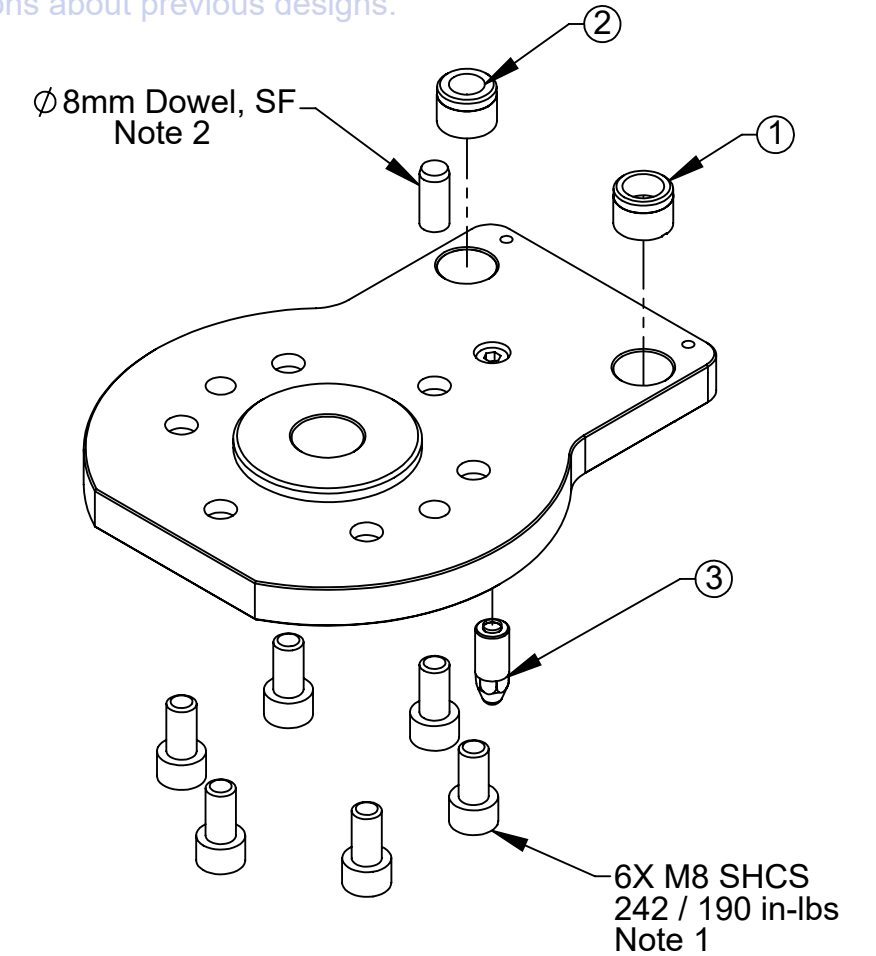

Notes:

1. Fasteners shipped loose. Customer to use loctite or similar thread locker and torque to listed value.
2. Dowel shipped loose. Customer to press dowel into ATI Tool Changer.

ITEM NO.	QTY.	PART NUMBER	DESCRIPTION
3	1	9120-TSS-HBQ-7539	TSS Tooling Interface Plate for QC-41 - Blank
NOTES: UNLESS OTHERWISE SPECIFIED.		<p>1031 Goodworth Drive, Apex, NC 27539, USA Tel: +1.919.772.0115 Fax: +1.919.772.8259 www.ati-ia.com ISO 9001 Registered Company</p>	
DO NOT SCALE DRAWING. ALL DIMENSIONS ARE IN MILLIMETERS.		<p>PROPERTY OF ATI INDUSTRIAL AUTOMATION, INC. NOT TO BE REPRODUCED IN ANY MANNER EXCEPT ON ORDER OR WITH PRIOR WRITTEN AUTHORIZATION OF ATI.</p>	
<p>DRAWN BY:</p> <p>CHECKED BY: J. Winterroth, 11/07/13</p>		<p>TITLE</p> <p>TSS Tooling Interface Plate for QC-41 - Blank</p>	
<p>PROJECT #</p> <p>SHEET 1 OF 1</p>		<p>SCALE</p> <p>1:2</p>	<p>SIZE</p> <p>B</p>
		<p>DRAWING NUMBER</p> <p>9630-20-TSS-HBQ-7539</p>	<p>REVISION</p> <p>05</p>

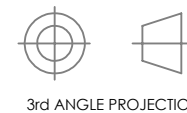

3rd ANGLE PROJECTION